

SECTION 33 1001 – SCOTTS MILLS WATER UTILITIES

PART 1 - GENERAL

1.1 DESCRIPTION

- A. The following specification section outlines the means, materials, and methods for new water system installations within the City of Scotts Mills.
- B. This specification does not take precedence over existing City of Scotts Mills policies regarding the water system and related utilities.
- C. No exceptions will be made for deviations from the means, materials, and methods listed herein without prior written approval from both the Scotts Mills Water System Engineer and the Scotts Mills Water Commissioner. Appeals may be may to the City Council, the Scotts Mills City Council meets once monthly.
- D. Additional requirements above and beyond these specifications for fire hydrants may be required by the Silverton Fire District.
- E. Where not listed in these specifications, water system design and construction shall follow AWWA specifications. The City of Scotts Mills reserves the right of final approval of all water systems within the City limits.
- F. Roadway restoration shall comply with Marion or Clackamas County standards or Oregon State Department of Transportation where applicable.

1.2 DESIGN STANDARDS

- A. All new water mains constructed for new developments of three (3) or more home sites shall be looped such that there are two connections to the Scotts Mills water system a minimum of twenty five feet (25') apart. This is to ensure proper domestic water circulation and appropriate fire flow. An exception may be made for new mains shorter than fifty feet (50') at the discretion of the City of Scotts Mills Water System Engineer or Water Commissioner. All exceptions shall be in writing.
- B. Minimum bury depth to top of pipe for all new water mains shall be thirty-six inches (36").
- C. All new water lines, fire hydrants, and other water system appurtenances shall be installed in the public right-of-way. Where water lines, fire hydrants, and other water system appurtenances are on private property, a fifteen foot (15') wide utility easement shall be dedicated and recorded for maintenance access. Copies of the easement shall be provided to the City of Scotts Mills and the Silverton Fire District.
- D. Bedding around new water mains shall be a minimum of nine inches (9") outside of the pipe diameter.

- E. Water main size shall be as determined by the City of Scotts Mills Water System Engineer. Minimum size for a new water main in the public right-of-way or in an easement is six-inch (6") diameter.
- F. Minimum size for service lines is one inch (1").
- G. All design plans are to be reviewed by the City of Scotts Mills and the City of Scotts Mills Engineer prior to any construction.

PART 2 – PRODUCTS

2.1 MATERIALS

- A. All water main pipe two-inch (2") and larger under paved surfaces (supporting vehicle traffic) shall be ductile iron pipe, Class 52 with Tyton joint gaskets as manufactured by Pacific States Cast Iron Pipe.
- B. All water main pipe two-inch (2") and larger outside of paved surfaces shall be ductile iron pipe as listed in Item A or C900 PVC Pipe, Class 150, DR18.
- C. All non-metallic pipe shall have a 12-gauge tracer wire six inches (6") above the pipe for locating purposes.
- D. All mainline water line fittings shall be ductile iron C153 as manufactured by Tyler/Union with megalugs. All fittings shall be manufactured domestically, no exceptions.
- E. Megalugs and restrained joint fittings shall be used in lieu of concrete thrust blocks.
- F. All water lines two inch (2") and smaller shall be Wirsbo Upanor Awuapex FI922000.
- G. All main line taps shall be Mueller tapping sleeves, stainless steel.
- H. All service saddles shall be Romac 202N service saddles with stainless steel straps for one-inch (1") pipe.
- I. All service saddles shall be Romac 202N with stainless steel straps for one-and-a-half inch (1-1/2") and larger.
- J. All new water meters shall be FlowIQ 2100 RF; 25 GPM 5/8" x 3/4"; lead-free PPS flow tube; 9-digit display; cubic feet registration. Type Number- 02U-57-C04-8UX, no exceptions.
- K. All new fire hydrants shall be Mueller Super Centurion 250 5-1/4 dry barrel fire hydrants, no exceptions. All pipe between fire hydrant and isolation/resilient seat gate valve shall be Class 52 ductile iron pipe.

- L. All new water main valves and fire hydrant valves shall be manufactured by Mueller. All new main line valves two inch (2”) and larger shall be Mueller resilient wedge gate valves, #A-2360-16. All valve boxes shall be 910 valve boxes.
- M. All fittings, angle stops, and corporation stops shall be Mueller.
- N. All meter boxes (for one inch (1”)) shall be Brooks No. 38 water meter boxes.
- O. All meter boxes (for one-and-a-half inch (1-1/2”) and larger) shall be Brooks No. 65 water meter boxes.
- P. All blow-offs shall be brass materials only.
- Q. Air-release valves shall be APCO, model number 207.

PART 3 – EXECUTION

3.1 QUALIFICATIONS

- A. Water line contractor shall have a minimum of two years’ experience installing water lines and a minimum of two thousand feet (2,000’) of water line installation six inch (6”) or larger. The developer shall provide the City of Scotts Mills with project names and locations of past projects to meet these minimum requirements a minimum of thirty (30) days before any work is done on the project. Water line contractors that do not meet these minimum requirements will not be allowed to work on City of Scotts Mills projects.

Pre-qualified contractors include:

- GT Excavating LLC
- (This list may be updated periodically, please check with the Water Commissioner)

- B. All main line hot taps shall be done by a City of Scotts Mills prequalified water line contractor:
 - 1. K&R Plumbing
 - 2. A&A Drilling
 - 3. D&M Excavating
 - 4. GT Excavating LLC

3.2 MAIN LINE TAP

- A. Main line tap locations to be verified with the City of Scotts Mills Water Commissioner prior to excavation.
- B. All taps shall be hot taps.

3.3 TRENCH CONSTRUCTION

- A. Trench width shall be eighteen inches (18”) wider than the width of the pipe. Bedding shall be a minimum of nine inches (9”) around the pipe.
- B. Backfill shall be compacted to 95% compaction density. Water compaction is not allowed.

3.4 SERVICE CONNECTIONS

- A. Service line tap locations shall be verified with the City of Scotts Mills Water Commissioner prior to installation.
- B. All water meters being replaced or moved shall have new service lines installed to the main. Damaged meters or meter boxes shall be replaced.

3.5 BLOWOFFS

- A. Blow-offs shall be a two inch (2”) tap, two inch (2”) blow-off with a three-quarter inch ($\frac{3}{4}$ ”) drain valve. Top of blow-off shall be a two inch (2”) brass plug, not a cap. Blow-off shall be no less than six inches (6”) from the top of the valve box.

3.6 FIRE HYDRANTS

- A. The shut-off valves for fire hydrants shall be installed a minimum of four feet (4’) from the hydrant.
- B. The spool between the valve and hydrant shall be Class 52 ductile iron pipe.
- C. The area around the fire hydrant shall be clear of all obstructions including landscaping for a minimum of four feet (4’) in all directions.

3.7 CONCRETE COLLAR

- A. All valve, air-release valves, and blow-offs shall have a fiber-reinforced concrete collar around them at ground level. Concrete shall be a minimum of 3,500 psi strength. Collar shall be a minimum of twelve inches (12”) wide all around and a minimum of six inches (6”) deep. All hydrants shall have a four foot by four foot (4’ x 4’) concrete pad around them. Hydrant pad shall be same strength concrete and 4” depth.

3.8 TESTING AND DISINFECTION

- A. Hydrostatic Testing:
 - I. Contractor shall make pressure and leakage tests on all newly laid pipe; follow the procedures specified in AWWA C-605, Section 5.2 “Hydrostatic Testing.” Contractor shall furnish all necessary equipment and material, make all taps in the pipes as required, and conduct the tests. The Water Commissioner or authorized

representative will monitor the tests and assure that all taps are installed, and service pipe extended.

2. Furnish the following equipment and materials for the tests:

<u>Amount</u>	<u>Description</u>
2	Pressure gauges
1	Hydraulic force pump approved by the Water Commissioner
1	Suitable hose and suction, as required

3. Conduct the tests after the trench is backfilled or partially backfilled with the joints left exposed for inspection, or when completely backfilled, as permitted by the Water Commissioner.
4. Conduct pressure tests in the following manner, unless otherwise approved by the Public Works Department authorized representative.
- After the trench is backfilled or partially backfilled as specified here, fill the pipe with water, expelling all air during the filling. The minimum test pressure shall be 150 psi. For lines working with operating pressures in excess of 100 psi, the minimum test pressure shall be 1½ times the operating pressure at the point of testing, however, test pressure shall not exceed pipe or thrust-restraint design pressures. The duration of each pressure test shall be 2 hours, unless otherwise directed by the Water Commissioner.
 - Procedure: Fill the pipe with water and apply the specified test pressure by pumping, if necessary. Then valve off the pump and hold the pressure in the line for the test period. Test pressure shall not vary by more than ±5 psi for the duration of the test. At the end of the test period, operate the pump until the test pressure is again attained. The pump suction shall be in a barrel or similar device or metered so that the amount of water required to restore the test pressure can be measured accurately.
5. Leakage: Leakage shall be defined as the quantity of water necessary to restore the specified test pressure at the end of the test period. No pipe installation will be accepted if the leakage is greater than the number of gallons per hour, as determined by the following formula: $L = SD(P)^{1/2} / 133,200$ Where: L = allowable leakage (gallons per hour). S = length of pipe to be tested (feet). D = nominal diameter of pipe (inches). P = average test pressure during the leakage test (psi).
6. Correction of Excessive Leakage: Should any test of laid pipe disclose leakage greater than that allowed, locate and repair the defective joints or pipe until leakage in a subsequent test is within the specified allowance.

- B. Sterilization: Pipeline intended to carry potable water shall be sterilized before it is placed in service. Disinfection by chlorination for pipelines shall be accomplished according to AWWA C-651, as modified or expanded below, and City requirements.
- C. Flushing: Before sterilizing, flush all foreign matter from the pipeline. Contractor shall provide hoses, temporary pipes, ditches, etc., as required to dispose of flushing water without damaging adjacent properties. If flushed into a sewer system, the contractor shall provide screening and remove all accumulated construction debris, rocks, gravel, sand, silt, and other foreign material from the system at or near the closest downstream manhole; no material shall be flushed into the downstream city sewer system. Flushing velocities shall be at least 2.5 feet per second (fps). For large-diameter pipe that is impractical or impossible to flush at 2.5 fps, clean the pipeline in place from the inside by brushing and sweeping, flush the line at a lower velocity.
- D. Sterilizing Mixture:
1. A solution with a free chlorine residual of at least 25 mg/l must be introduced to the pipe such that the solution will contact all surfaces and trapped air will be eliminated. The solution must remain in place for at least 24 hours.
 2. Point of Application:
 - a. Inject the chlorine mixture into the pipeline to be treated at the beginning of the line through a corporation stop or a suitable tap in the top of the pipeline. Water from the existing system or other approved source shall be controlled to flow slowly into the newly laid pipeline during the application of chlorine. The proportion of the flow rate of the chlorine mixture to the rate of water entering the pipe shall be such that the combined mixture shall contain 40 to 50 ppm of free available chlorine.
 - b. Valves shall be manipulated so that the strong chlorine solution in the line being treated will not flow back into the line supplying the water. Use check-valves if necessary.
 - c. Operate all valves, hydrants, and other appurtenances during sterilization to assure that the sterilizing mixture is dispersed into all parts of the line, including dead ends, new services, and similar areas that otherwise may not receive the treated water.
 - d. Do not place the concentrated quantities of commercial sterilizer in the line before it is filled with water.
 - e. After chlorination, flush the water from the line, see “Disposal of Flushing and Sterilizing Water”, until the water through the line is equal chemically and bacteriologically to the permanent source of supply. NOTE: When testing and sterilizing procedures are complete, remove the testing corporation stop and replace it with a threaded brass plug. NOTE: The practice of adding a small amount of chlorine powder or tablets at each joint as the main is being laid is not an acceptable method of chlorinating a pipeline.
 - f. Retention Period: After 24 hours, if the free chlorine residual is 10 mg/l or greater, the chlorine solution must be drained and the pipe flushed with potable water. If the free chlorine residual is less than 10 mg/l after 24-

hours, the pipe must be flushed and dechlorinated until a free chlorine residual of 10 mg/l or more is present after a 24-hour period.

- g. Disposal of Flushing and Sterilizing Water:
- 1) Dispose of flushing and sterilizing water in a manner approved by the Water Commissioner. If the volume and chlorine concentration is such as to pose a hazard to the City's Wastewater Treatment Plant operation, the sterilizing water shall be metered into the system per direction of the Water Commissioner. Notify the Water Commissioner at least 24 hours or one business day before disposing of sterilizing water.
 - 2) Do not allow sterilizing water to flow into a waterway or storm line without reducing the chlorine to a safe level via adequate dilution or another neutralizing method
 - 3) Bacteria Testing:
 - a) After the pipe is disinfected, flushed and filled with potable water, bacteriological samples must be collected to determine the procedures' effectiveness. At least two samples must be collected from the new pipe at least 16 hours apart and analyzed for coliform bacteria. If the pipe has held potable water for at least 16 hours before sample collection, two samples may be collected at least 15 minutes apart while the sample tap is left running. If the results of both analyses indicate the water is free of coliform bacteria, the pipe may be put into service. If either sample indicates the presence of coliform bacteria, the pipe may be re-flushed, filled with potable water and re-sampled. If this second set of samples is free of coliform bacteria, the pipe may be put into service, otherwise the disinfection and flushing process must be repeated until samples are free of coliform.

END OF SECTION

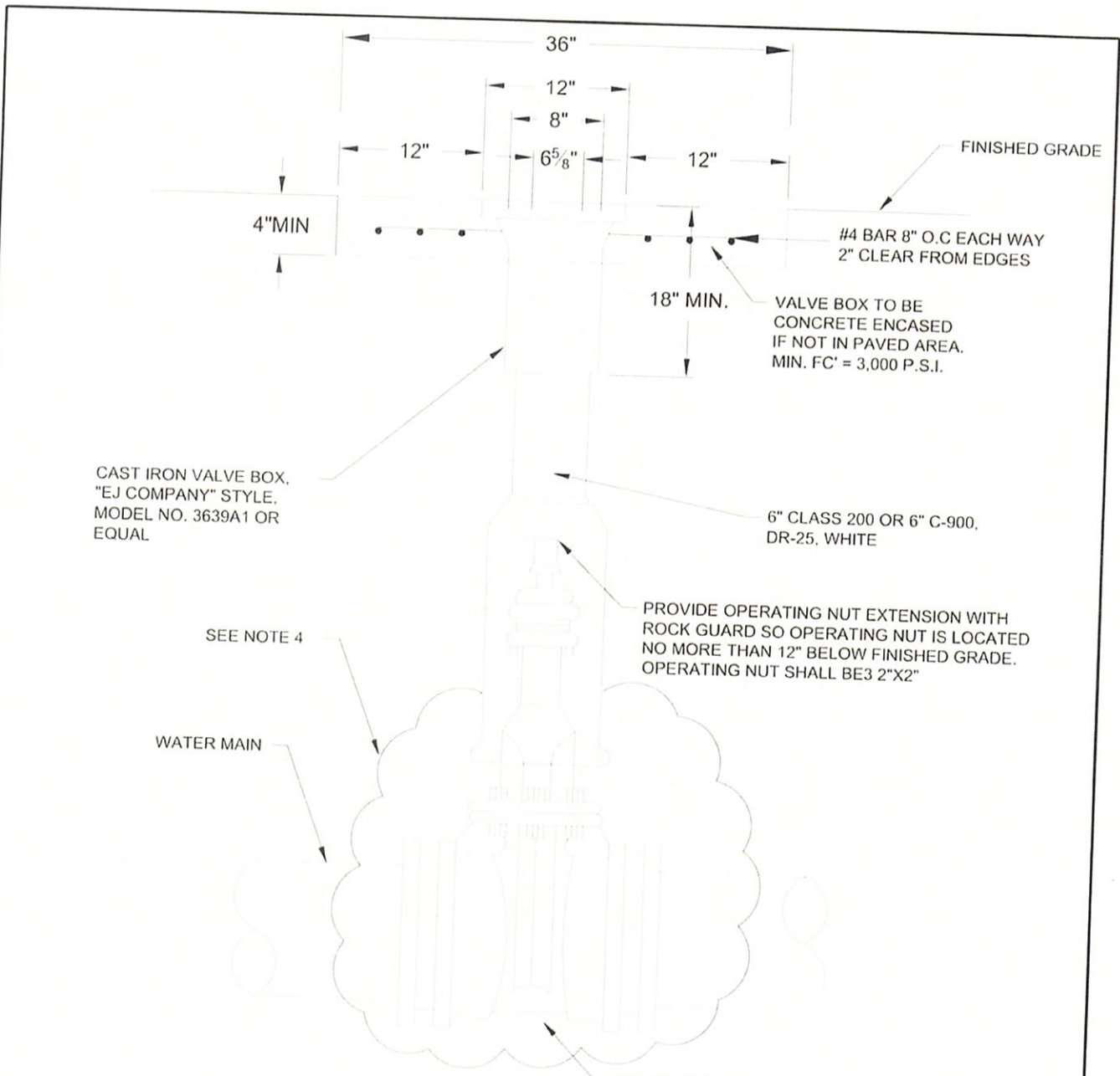

NOTES:

1. VALVE BOXES SHALL BE CENTERED DIRECTLY OVER THE VALVE NUT IN A VERTICAL POSITION.
2. VALVE BOX TOP SHALL BE ADJUSTED TO MEET FINISHED GRADE.
3. VALVES 8" AND SMALLER SHALL BE MJ GATE VALVES.
4. WRAP VALVE WITH V-BIOPOLYETHYLENE ENCASUREMENT PRIOR TO BACKFILLING. EXTEND POLYETHYLENE 6" MINIMUM BEYOND VALVE AND SECURE TO PIPE WITH 10 MIL PVC TAPE.
5. MINIMUM WATER LINE BURY DEPTH IS 36".

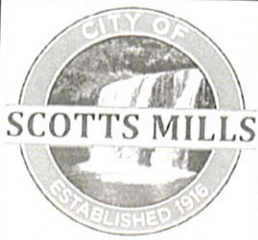

CITY OF SCOTTS MILLS
WATER SYSTEM STANDARD DETAILS

WATER VALVE

DATE APPR.
 11/22/20
 SCALE
 NTS
 DETAIL NO
 SM-001

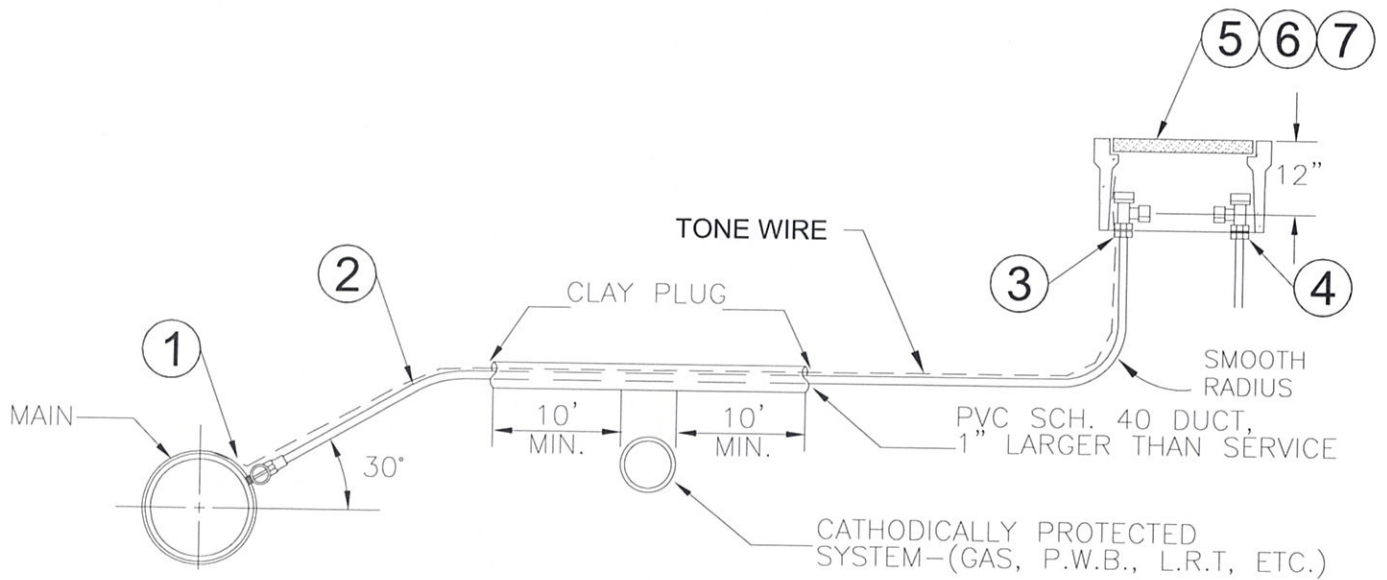

MATERIALS:

1. ROMAC 202N SERVICE SADDLE. CASTING MUST BE BLACK OR BLUE NYLON OR EPOXY COATED, AND BOTH STRAPS MUST BE TYPE 304 STAINLESS STEEL, HEAVY GAUGE, OR APPROVED EQUAL WITH MUELLER LOW LEAD CORP STOP B-2508N (1") OR APPROVED EQUAL.
2. ALL WATER LINES TWO INCH (2") AND SMALLER SHALL BE WIRSBO UPANOR AWUAPEX FI922000
3. ANGLE METER STOP: MULLER LOW LEAD 300 SERIES B24258, 1", OR APPROVED EQUAL.
4. CUSTOMER SIDE SHUTOFF: MULLER LOW LEAD 300 SERIES B-24258, 1", OR APPROVED EQUAL.
5. METER BOX BODY (BROOKS 38 CONCRETE METER BOX BODY 18"W X 27-1/2"L OD).
6. METER BOX COVER (BROOKS 38-2 CONCRETE COVER LESS LID. 13-3/4" X 23-1/4").
7. METER BOX LID (BROOKS #2 CI LID ONLY FOR 65-S & 38-S COVER 7" x 13" 2-713L-CI), OR APPROVED EQUAL.
8. 12 GAUGE SOLID TONE WIRE, BLUE.

NOTES:

1. SUBSTITUTES FOR ANY MATERIALS SHOWN SHALL BE APPROVED PRIOR TO CONSTRUCTION BY THE WATER COMMISSIONER.
2. ALL PIPE AND STRUCTURE ZONES SHALL BE BACKFILLED USING 3/4"-0 CRUSHED AGGREGATE AND COMPACTED TO 95% MAXIMUM DENSITY AS DETERMINED BY AASHTO T-180.
3. METER BOX SHALL BE H-20 LOAD RATED AND CENTERED OVER THE COMPLETED METER ASSEMBLY.
4. METER BOX SHALL BE LOCATED IN PLANTER AREAS OR AS APPROVED BY THE WATER COMMISSIONER.
5. EACH CONNECTION POINT IN THE ABOVE APPROVED MATERIALS LIST SHALL HAVE A "PEX" INSERT TO PREVENT THE PIPE FROM BENDING OR CRUSHING DURING INSTALLATION.



CITY OF SCOTT'S MILLS
WATER SYSTEM STANDARD DETAILS

STANDARD 1" WATER SERVICE

DATE APPR.	07/13/20
SCALE	NTS
DETAIL NO	SM-002

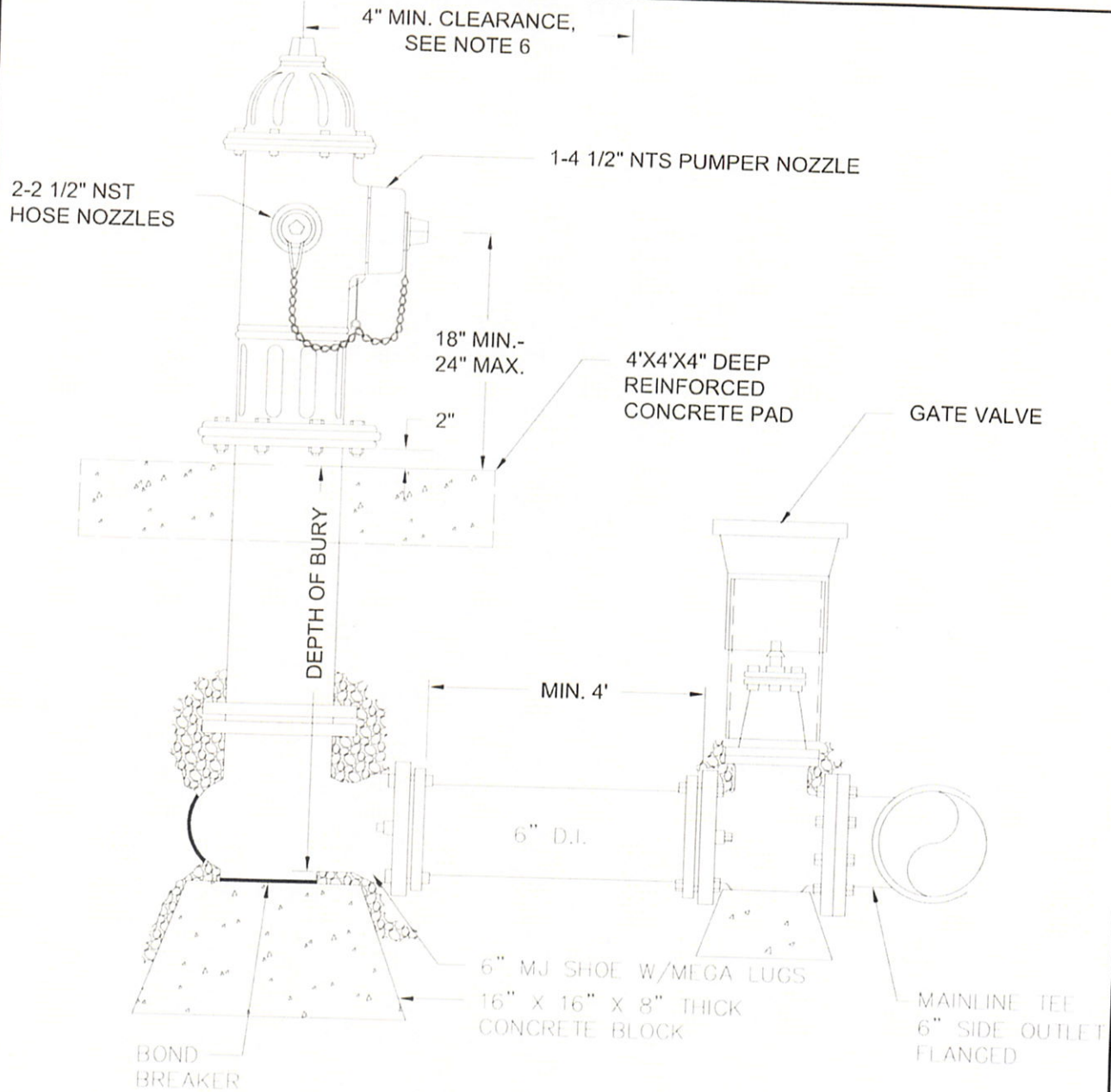

NOTES:

1. JOINTS TO BE RESTRAINED BY (4) 3/4" DIA. GALVANIZED STEEL RODS AT QUARTER POINTS BY USING FLANGED HYDRANT SHOE, GATE VALVE AND SPOOL.
2. ALL FITTINGS IN CONTACT WITH CONCRETE SHALL BE WRAPPED IN PLASTIC. HYDRANT DRAIN HOLES TO REMAIN OPEN TO DRAIN ROCK AND OPERATIONAL. DRAIN HOLES TO BE WRAPPED IN 6 MIL. PLASTIC.
3. 1-1/2" CLEAN DRAIN ROCK SHALL BE PLACED A MIN. OF 12" AROUND DRAIN OUTLET AND AROUND HYDRANT.
4. BURY OF HYDRANT SHALL BE MEASURED FROM FINISHED GRADE TO BOTTOM OF CONNECTING PIPE.
5. HYDRANT VALVE SHALL BE RESILIENT SEAT GATE VALVE ONLY.
6. PROVIDE A MINIMUM OF 4' CLEARANCE AROUND ENTIRE HYDRANT FOR ACCESS INCLUDING LANDSCAPING.
7. PROVIDE CONCRETE PAD AROUND HYDRANT AS SHOWN.

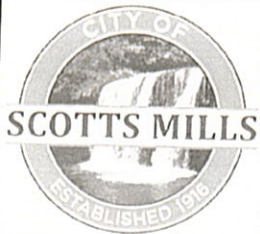

CITY OF SCOTT'S MILLS
WATER SYSTEM STANDARD DETAILS

STANDARD FIRE HYDRANT

DATE APPR.	11/22/20
SCALE	NTS
DETAIL NO	
	SM-003

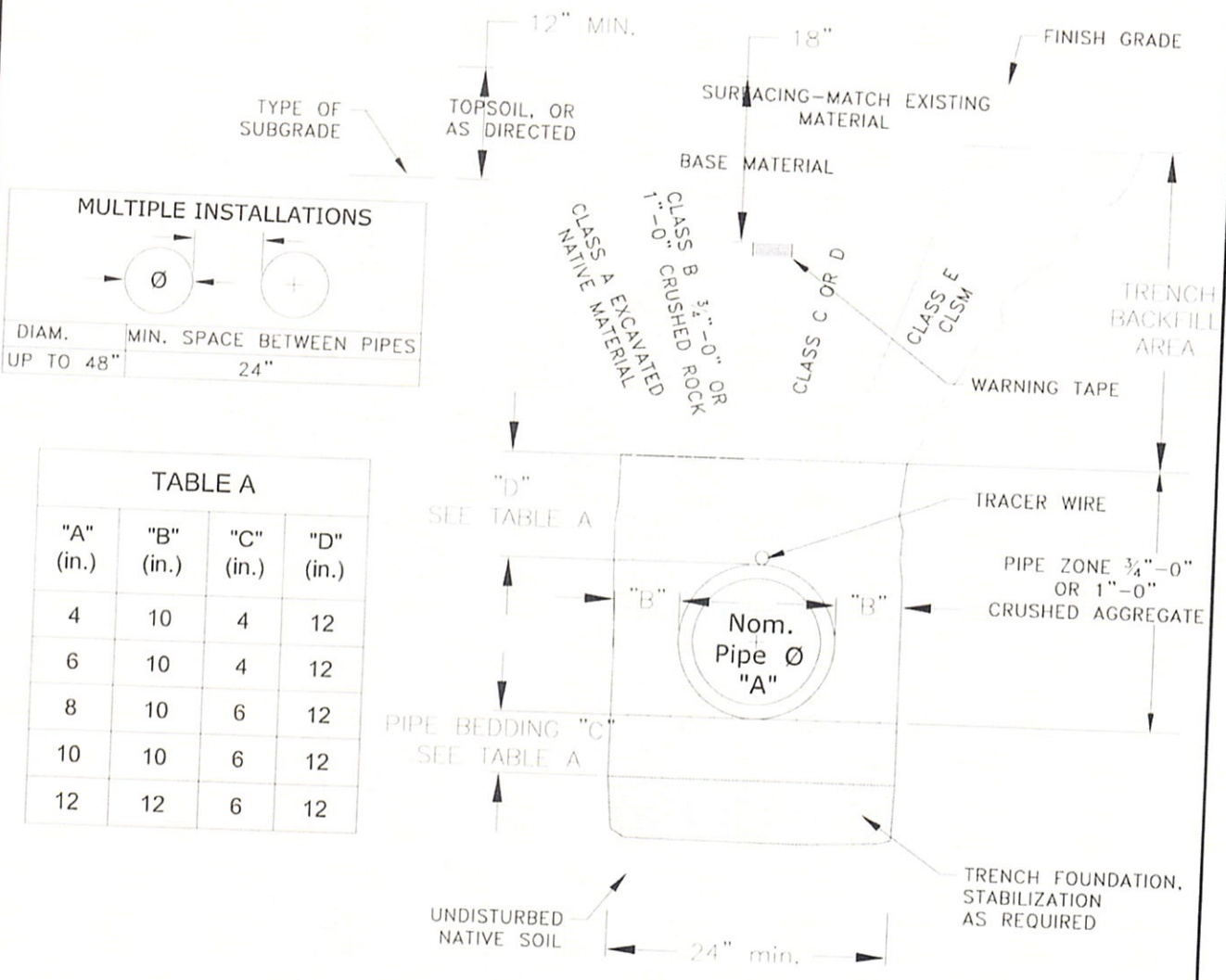
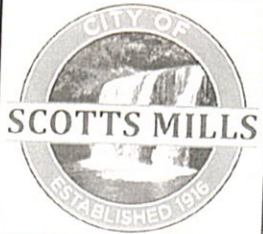

TABLE A

"A" (in.)	"B" (in.)	"C" (in.)	"D" (in.)
4	10	4	12
6	10	4	12
8	10	6	12
10	10	6	12
12	12	6	12



CITY OF SCOTT'S MILLS

WATER SYSTEM STANDARD DETAILS

STANDARD TRENCH SECTION

DATE APPR. 11/22/20

SCALE NTS

DETAIL NO SM-005

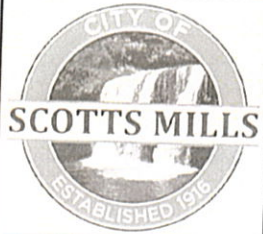
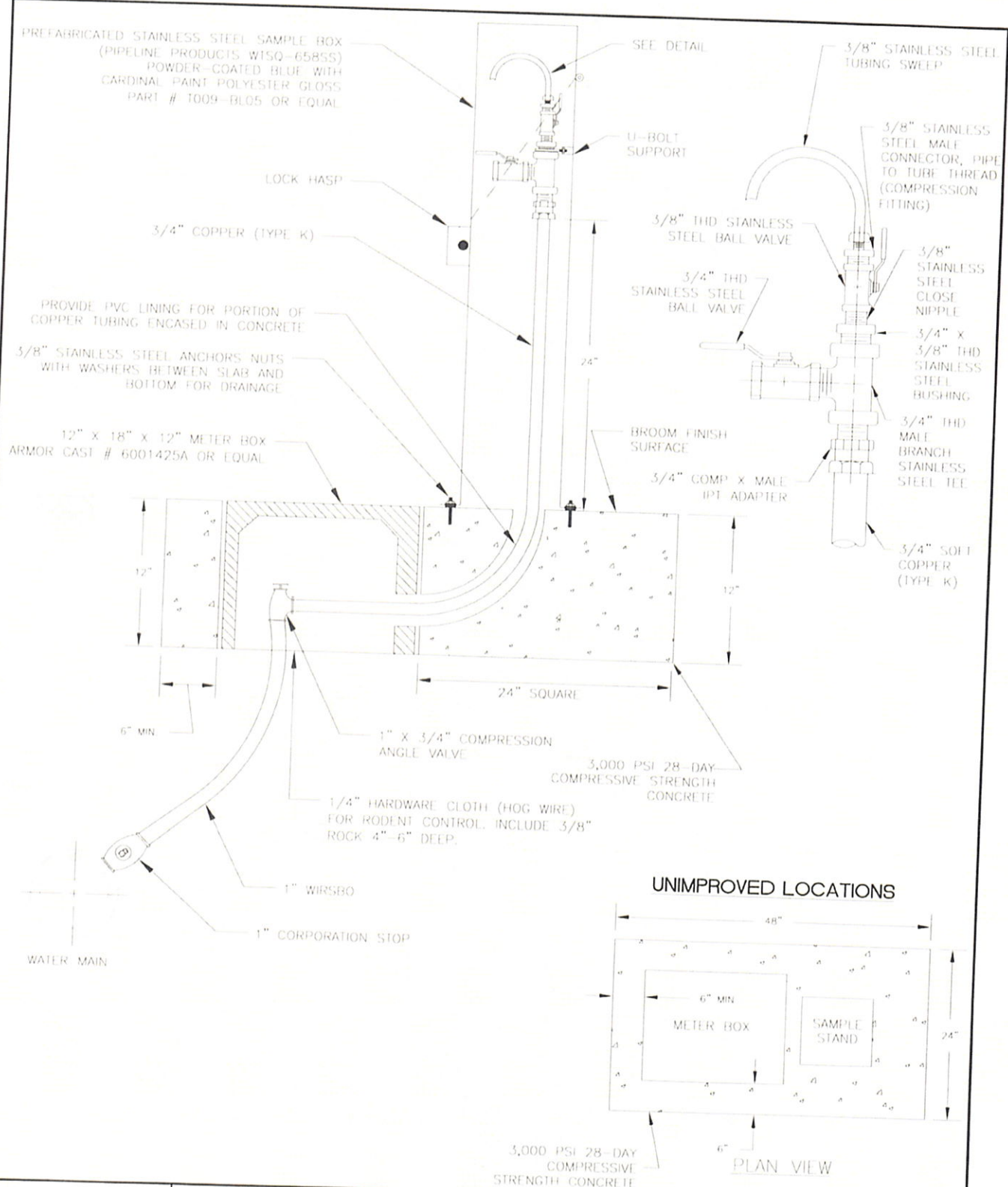

CITY OF SCOTT'S MILLS
WATER SYSTEM STANDARD DETAILS

TEST STATION

DATE APPR.	11/22/20
SCALE	NTS
DETAIL NO	SM-008

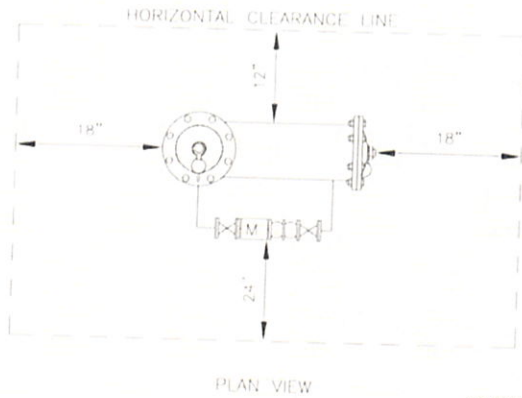

PLAN VIEW

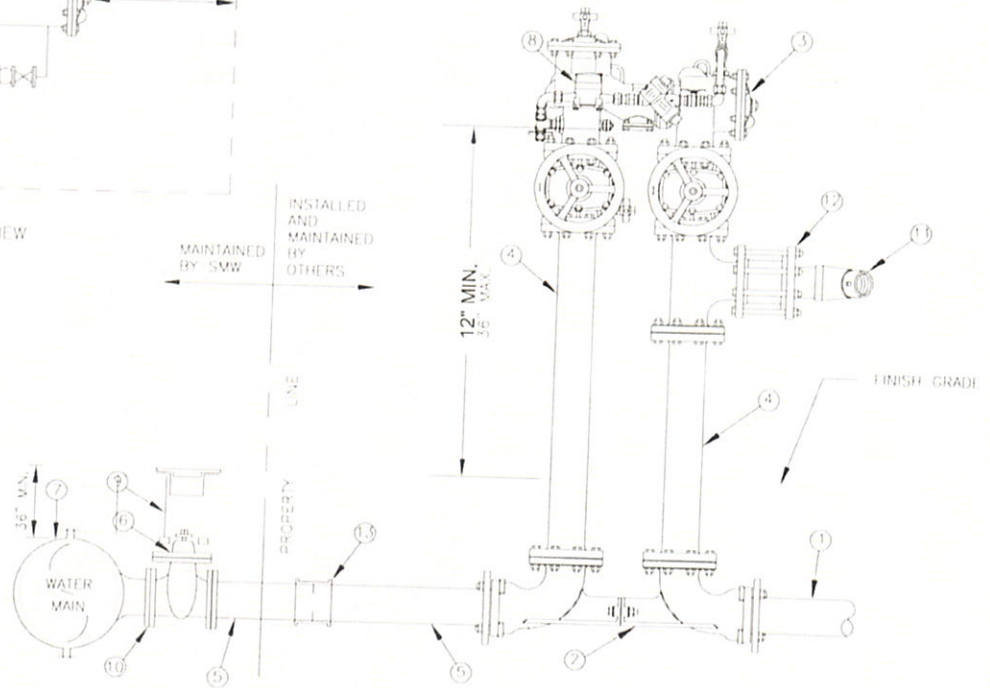

ITEM	QTY	DESCRIPTION
①	4 LF	STUB-OUT FOR SERVICE CONNECTION (MATERIAL SPECIFIED BY CUSTOMER)
②	1 EA	___" VALVE SETTER
③	1 EA	___" DOUBLE CHECK DETECTOR ASSEMBLY (FEBCO 876/876V OR APPROVED EQUAL)
④	2 EA	___" SCH. 40 STEEL OR DUCTILE IRON PIPE SPOOLS
⑤	___ LF	___" PRESSURE CLASS 350 DUCTILE IRON PIPE (RESTRAINED) SEE SBMWD SPECIFICATIONS FOR BACKFILL REQUIREMENTS
⑥	1 EA	___" FLANGE BY M.J. GATE VALVE ASSY PER SBMWD STD. DWG. W3.1
⑦	1 EA	EPOXY COATED TAPPING SLEEVE, MJ TAPPING SLEEVE, WELD NOZZLE, OR MJxFLG TEE ___" O.D. MAIN WITH ___" SERVICE LATERAL
⑧	1 EA	BYPASS METER THAT IS APPROVED BY THE DOUBLE CHECK DETECTOR ASSEMBLY MANUFACTURER SHALL BE FACTORY INSTALLED AND THE ACCOMPANYING FACTORY METER CERTIFICATE SHALL BE PROVIDED TO THE DEPARTMENT
⑨	1 EA	8" GATE VALVE CAN ASSEMBLY PER SBMWD STD. DWG. W3.3
⑩	1 EA	PIPELINE SEAL AND INSULATOR, INC INSULATING KIT TO BE USED BETWEEN THE TAPPING SADDLE AND VALVE WHEN DISSIMILAR METALS (DUCTILE IRON AND STEEL) ARE INVOLVED
⑪	1 EA	FIRE DEPARTMENT CONNECTION (FDC), SIZE, ORIENTATION, AND PROTECTIVE ENCLOSURE OR PROTECTIVE DEVICES SHALL BE COORDINATED, INSPECTED, AND APPROVED BY THE FIRE DEPARTMENT UPON INSTALLATION
⑫	1 EA	WAFER CHECK VALVE, AS DETERMINED BY THE FIRE DEPARTMENT
⑬	1 EA	SERIES 3800 RESTRAINED COUPLING (MEGA-COUPLING), OR APPROVED EQUAL

NOTES:

1. ANY BACKFLOW RELATED INSTALLATION AND/OR REPLACEMENT, INCLUDING PARTS, SHALL ADHERE TO THE MOST CURRENT CROSS-CONNECTION CONTROL STANDARDS.
2. SWAB INTERIOR OF PIPE, VALVES, AND FITTINGS, AND SWAB INTERIOR OF EXISTING MAINS TO WHICH NEW PIPING WILL BE CONNECTED (BOTH UPSTREAM AND DOWNSTREAM OF THE NEW BACKFLOW ASSEMBLY) WITH A 5% SODIUM HYPOCHLORITE SOLUTION. AFTER DISINFECTION, FLUSH WITH POTABLE WATER AGAIN UNTIL WATER IS FREE OF CHLORINE ODOR.
3. IF GIVEN A WAIVER TO INSTALL A BACKFLOW ASSEMBLY A CERTAIN DISTANCE FROM THE METER, THEN THE PIPING SHALL BE EXPOSED FROM THE SERVICE METER TO THE BACKFLOW ASSEMBLY WITH NO TEES OR CONNECTIONS, AND ENCASED IN A IWO SACK SLURRY MIX. THE WORK SHALL BE WITNESSED AND APPROVED BY WATER COMMISSIONER.

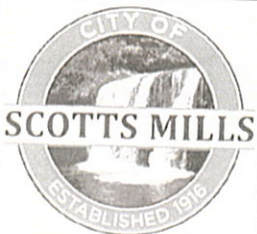

CITY OF SCOTT'S MILLS
WATER SYSTEM STANDARD DETAILS

FIRE SERVICE METER

DATE APPR.
11/22/20

SCALE
NTS

DETAIL NO

SM-009

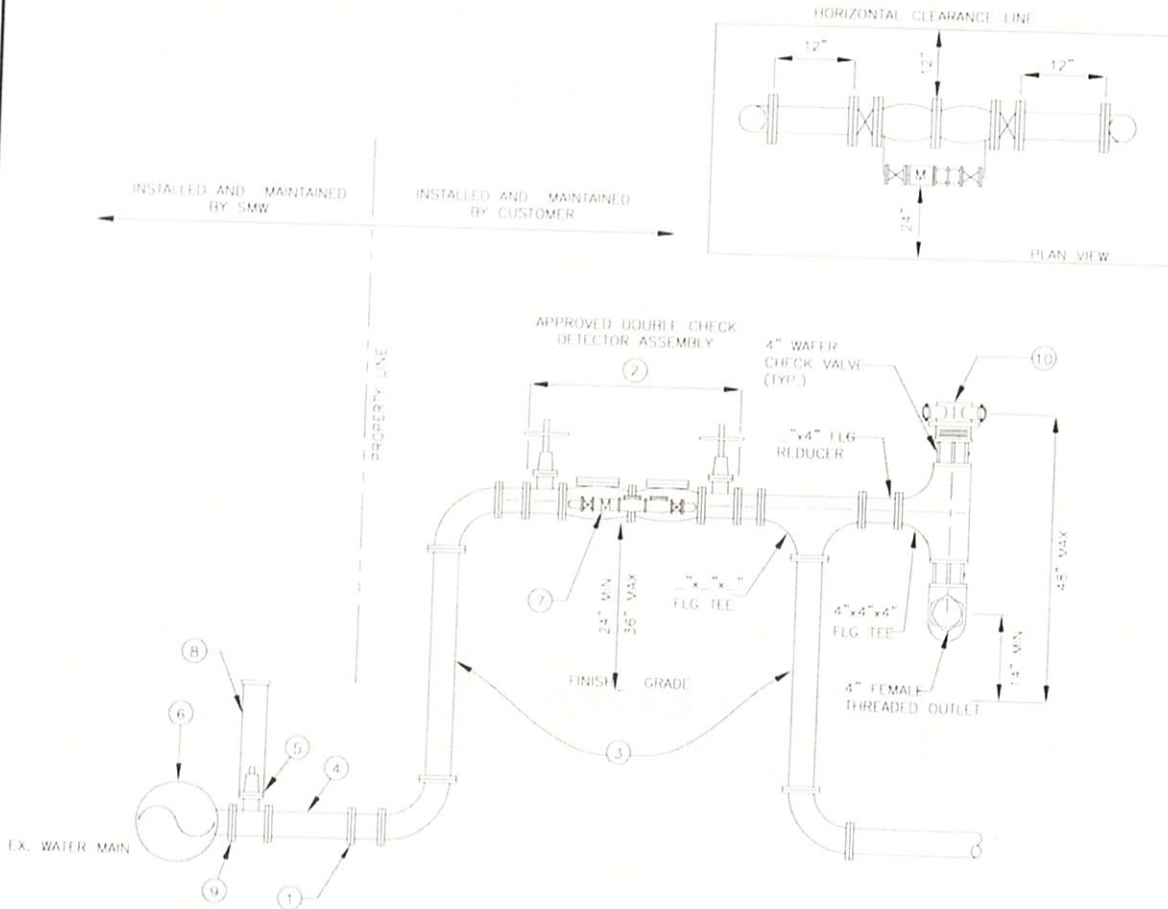

NOTES:

- ① INSTALL BLIND FLANGE AT CONNECTION POINT/PROPERTY LINE
- ② THE DETECTOR ASSEMBLY SHALL BE INSPECTED AND APPROVED BY SMW IMMEDIATELY AFTER INSTALLATION. THE ASSEMBLY MUST BE TESTED BY A CERTIFIED BACKFLOW TESTER.
- ③ 2 EA. ___" SCH. 40 STEEL OR DUCTILE IRON PIPE SPOOLS (RESTRAINED)
- ④ 1 EA. ___" PRESSURE CLASS 350 DUCTILE IRON (RESTRAINED) SEE SBMWD SPECIFICATIONS FOR BACKFILL REQUIREMENTS
- ⑤ 1 EA. ___" FLANGE BY M.J. GATE VALVE ASSEMBLY PER SBMWD STD. DWG. W3.1
- ⑥ 1 EA. EPOXY COATED TAPPING SLEEVE, MJ TAPPING SLEEVE, WELD NOZZLE, OR MJXFLG TEE ___" O.D. MAIN WITH ___" SERVICE LATERAL
- ⑦ 1 EA. BY-PASS METER THAT IS APPROVED BY THE DOUBLE CHECK DETECTOR ASSEMBLY MANUFACTURER SHALL BE FACTORY INSTALLED AND THE ACCOMPANYING FACTORY METER CERTIFICATE SHALL BE PROVIDED TO THE DEPARTMENT.
- ⑧ 1 EA. VALVE CAN ASSEMBLY PER SBMWD STD. DWG. W3.3
- ⑨ 1 EA. PIPELINE SEAL AND INSULATOR, INC INSULATING KIT TO BE USED BETWEEN THE TAPPING SADDLE AND VALVE WHEN DISSIMILAR METALS (DUCTILE IRON AND STEEL) ARE INVOLVED
- ⑩ 1 EA. FIRE DEPARTMENT CONNECTION (FDC), SIZE, ORIENTATION, AND PROTECTIVE ENCLOSURE OR PROTECTIVE DEVICES SHALL BE COORDINATED, INSPECTED, AND APPROVED BY THE FIRE DEPARTMENT UPON INSTALLATION.

NOTES:

- 1. ANY BACKFLOW RELATED INSTALLATION AND/OR REPLACEMENT, INCLUDING PARTS, SHALL ADHERE TO THE MOST CURRENT CROSS-CONNECTION CONTROL STANDARDS.
- 2. SWAB INTERIOR OF PIPE, VALVES, AND FITTINGS, AND SWAB INTERIOR OF EXISTING MAINS TO WHICH NEW PIPING WILL BE CONNECTED (BOTH UPSTREAM AND DOWNSTREAM OF THE NEW BACKFLOW ASSEMBLY) WITH A 5% SODIUM HYPOCHLORITE SOLUTION. AFTER DISINFECTION, FLUSH WITH POTABLE WATER AGAIN UNTIL WATER IS FREE OF CHLORINE ODOR.

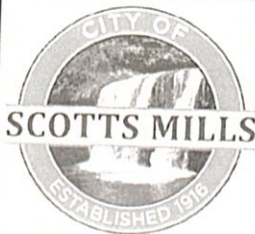

CITY OF SCOTT'S MILLS
WATER SYSTEM STANDARD DETAILS

DOUBLE CHECK VALVE BACKFLOW PREVENTER

DATE APPR.	11/22/20
SCALE	NTS
DETAIL NO	SM-010